

PHILIPS

sense and simplicity

Product integration process at Philips Healthcare MR

Godfried Webers

Bits & Chips Embedded Systems 2011



MR products



INTERA 1.5T, 3.0T



ACHIEVA 1.5T, 3.0T



PANORAMA HFO 1.0T



INGENIA 1.5T, 3.0T

Philips Healthcare MR is a global manufacturer of MR systems.



MR worldwide



CLEVELAND, USA



BEST, The Netherlands



HELSINKI, Finland



BANGALORE, India

SUZHOU, China

LATHAM, USA

- Product development
- Manufacturing
- Application
- Marketing

Philips Healthcare MR product development is organized worldwide



MR regulatory



Applicable **international standards** for medical devices impose requirements on product and development process

Philips Healthcare MR – QMS

- process descriptions
- work instructions
- document templates

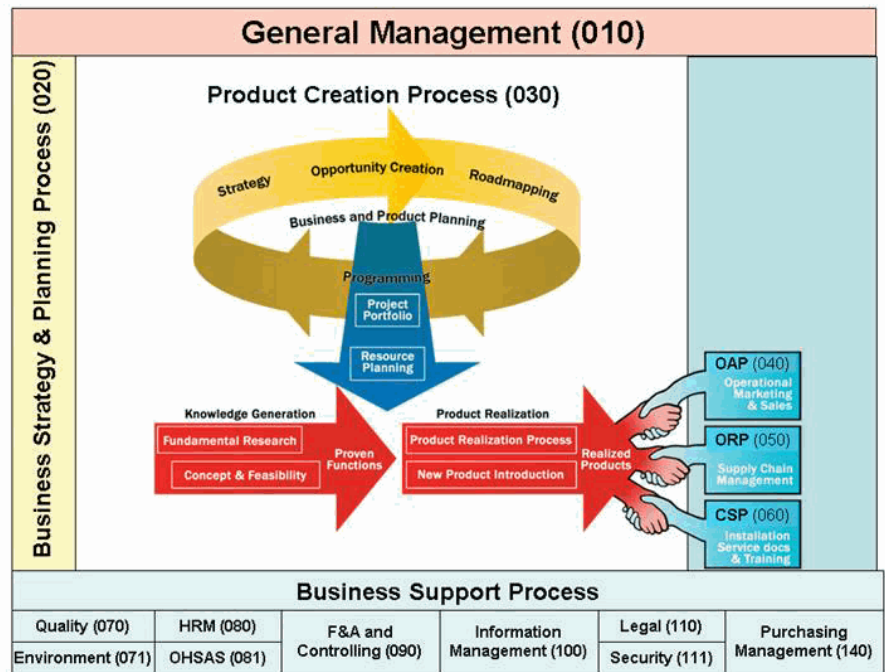

Philips Healthcare MR quality management system



MR processes

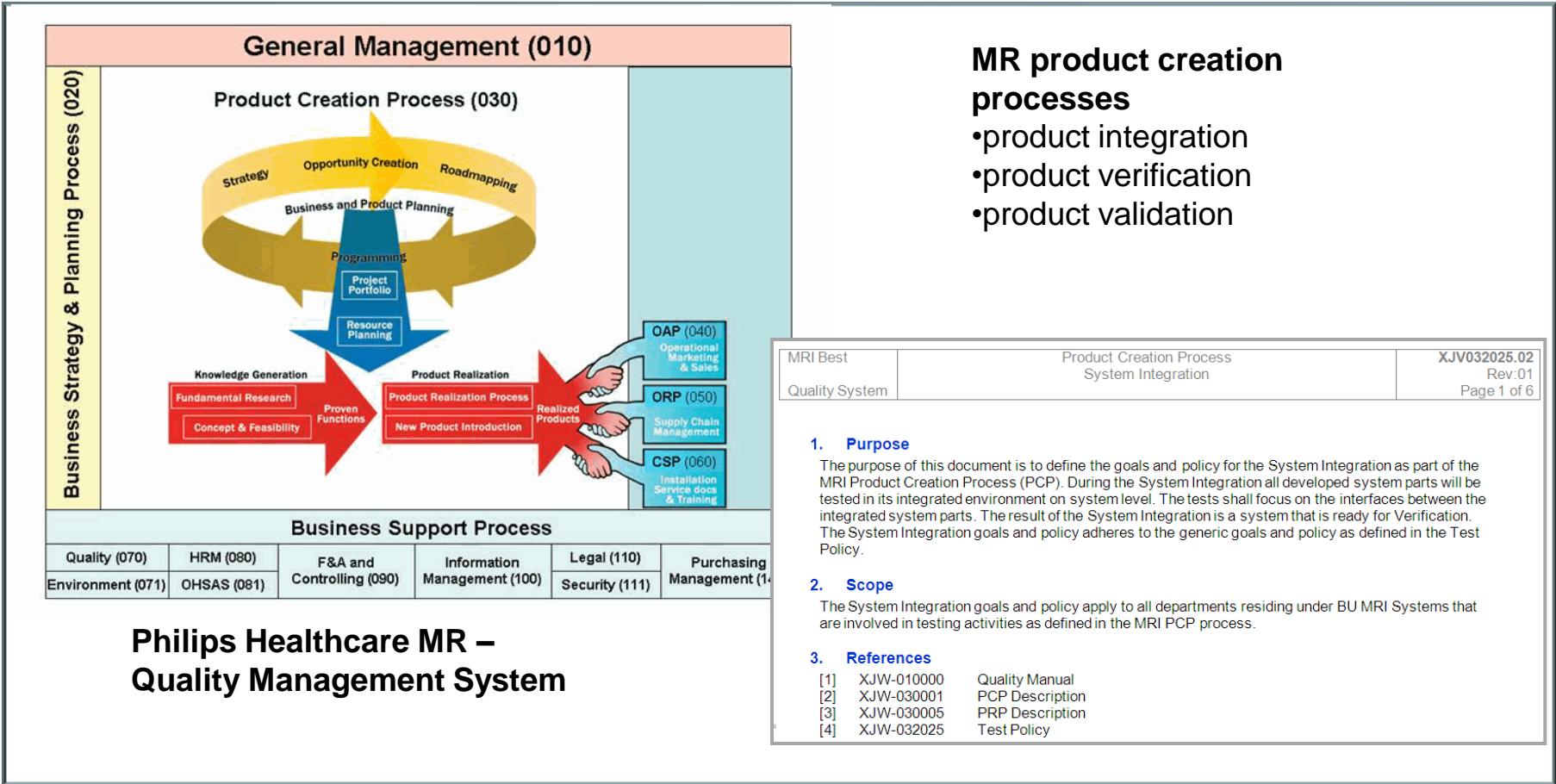

Philips Healthcare MR product creation processes



MR V-model

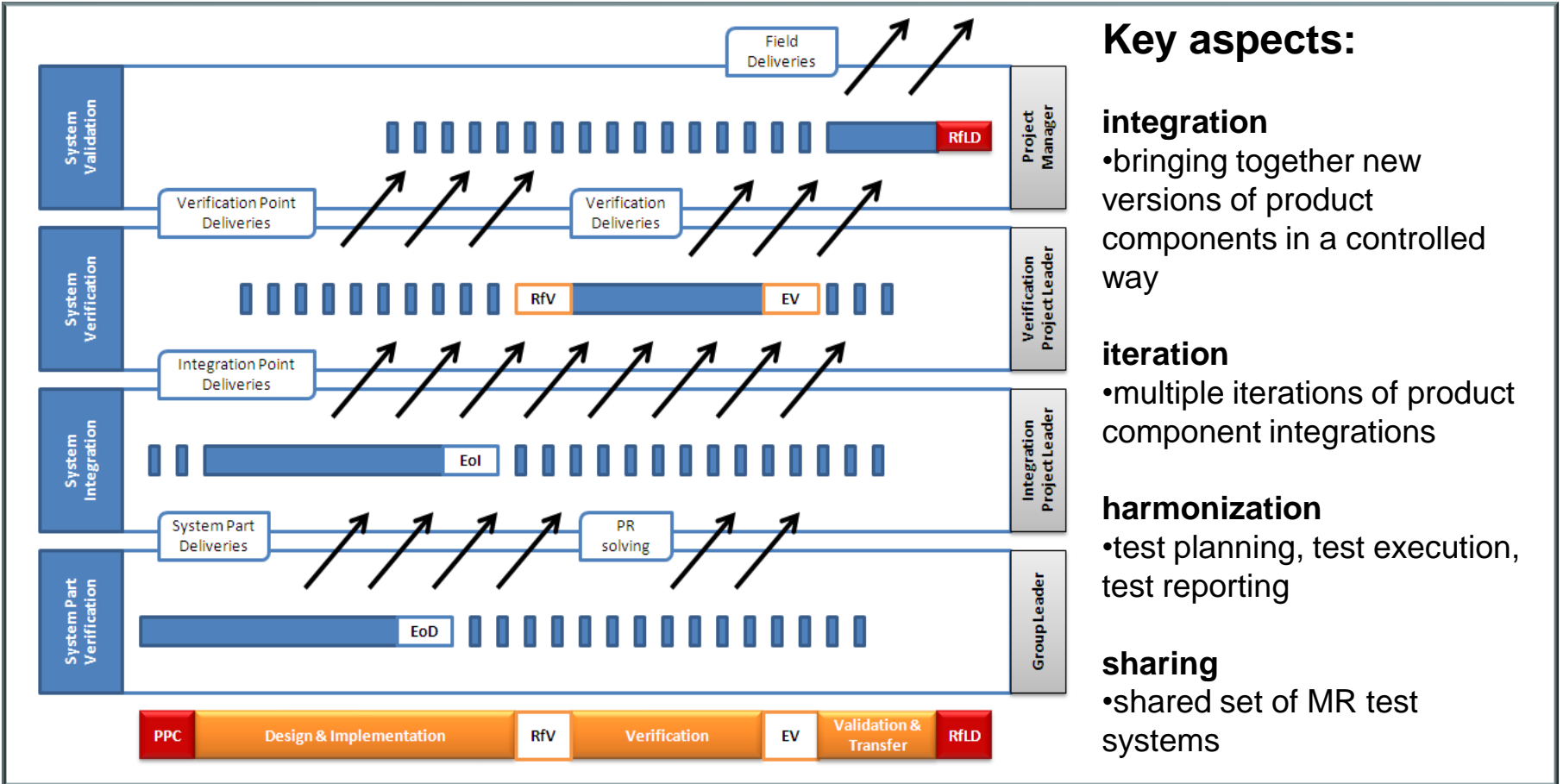

Key aspects:

integration

- bringing together new versions of product components in a controlled way

iteration

- multiple iterations of product component integrations

harmonization

- test planning, test execution, test reporting

sharing

- shared set of MR test systems

Philips Healthcare MR V-model



MR integration organization

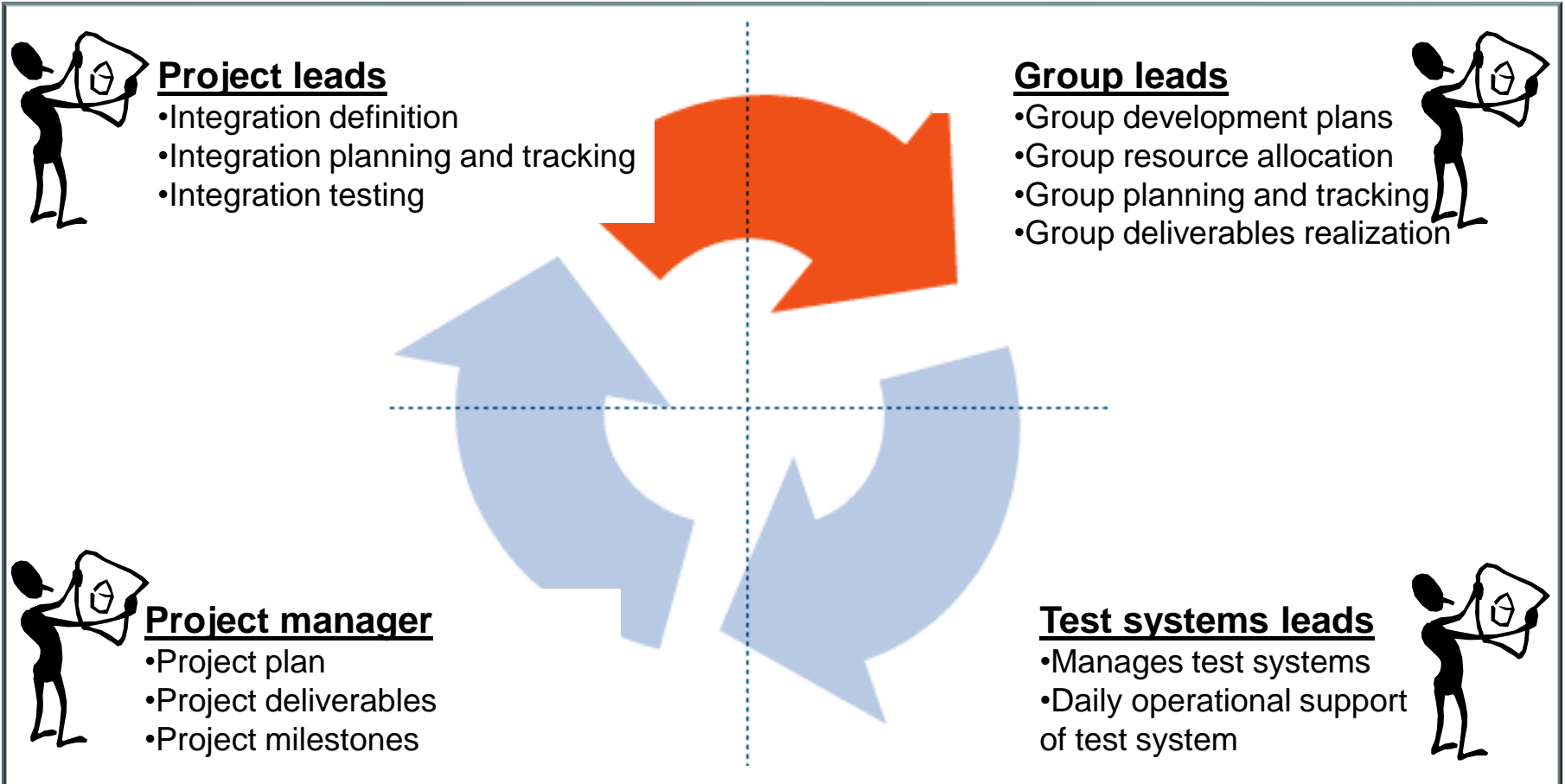

Philips Healthcare MR integration organization



MR integration practices

I. Integration sequence

- Integration building blocks
- Integration rationale
- Integration test focus

(CMMi-practice: “preparation for product integration”)



II. Component interfaces

- Interface management
- Backwards compatibility

(“CMMi-practice: product component interfaces are compatible”)

IV. Integration process

- Integration as a defined process

(CMMi-practice: “The process is institutionalized as a defined process”)

III. Integration environment

- Test environment management

(CMMi-practice: “Verified product components are integrated”)

Philips Healthcare MR integration practices



I. MR integration concepts

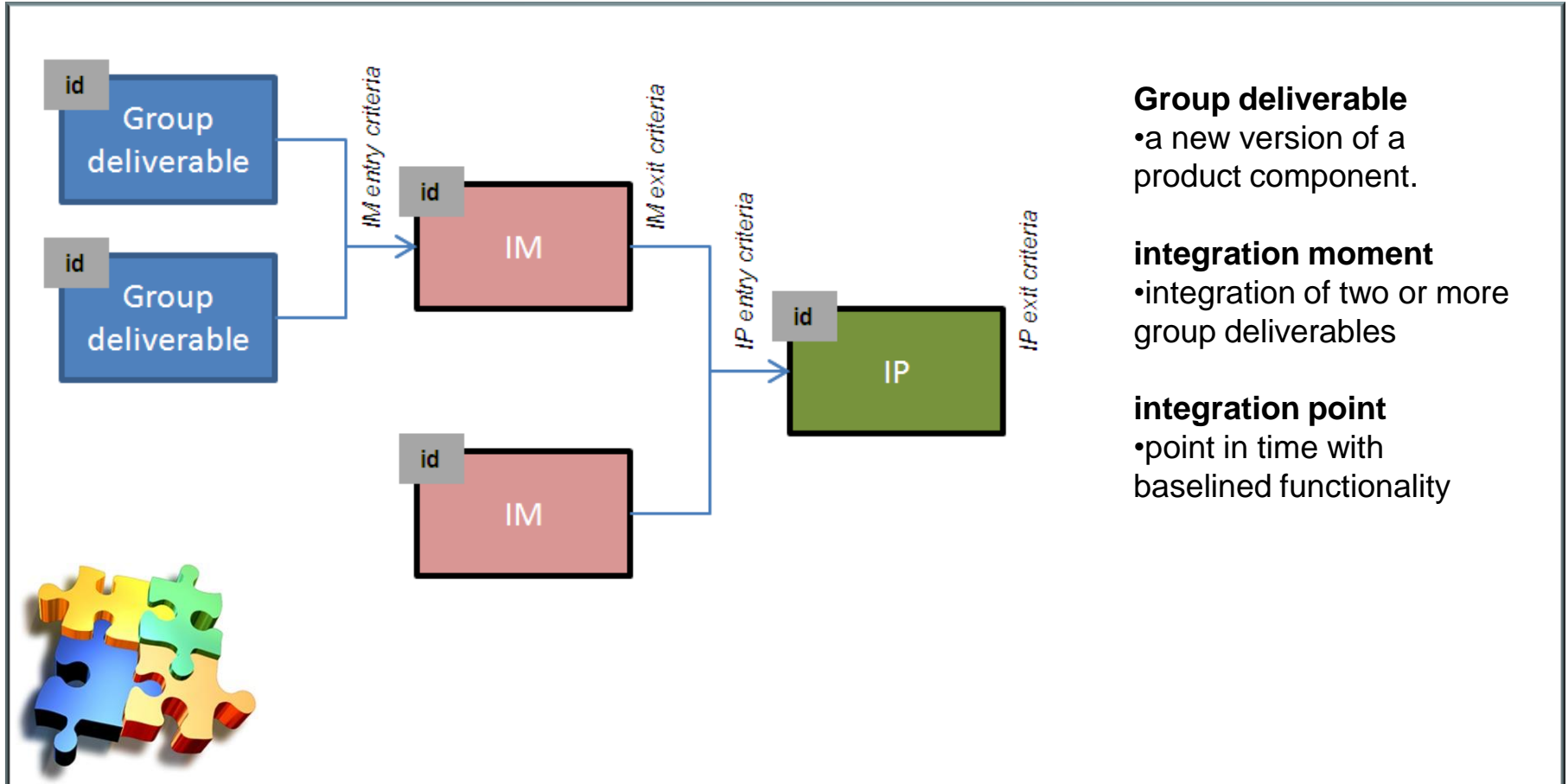

Group deliverable

- a new version of a product component.

integration moment

- integration of two or more group deliverables

integration point

- point in time with baselined functionality

Philips Healthcare MR integration concepts



I. MR integration sequence

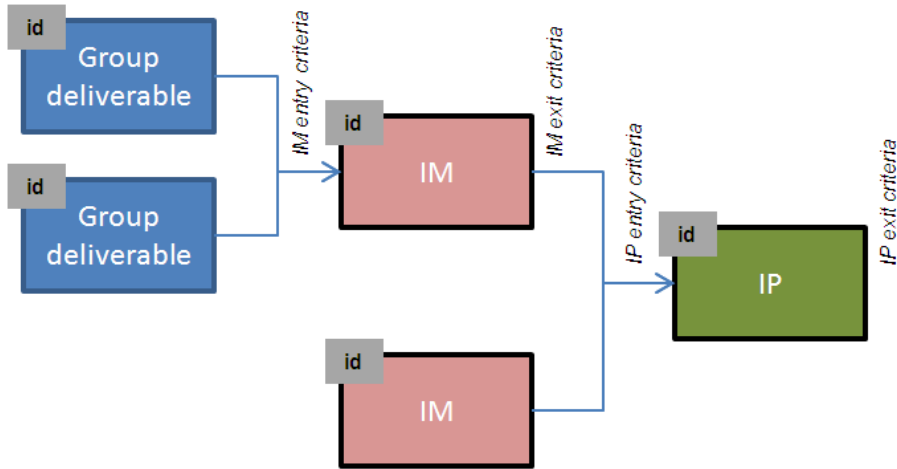

Integration Sequence:

- Goal:
 - Consolidate technical content
 - Consolidate planning of new versions of product components
- Inputs:
 - Project plan
 - Risk assessment
 - Resource planning
- Output:
 - Documented integration sequence
 - Documented integration test plans
- Updates:
 - Periodically reviewed



I. MR integration deliveries

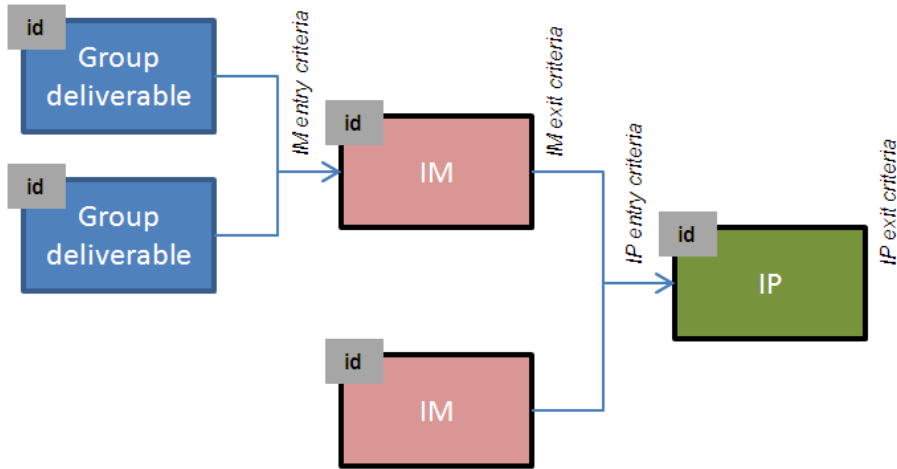

Integration Deliveries:

- Goal:
 - develop new versions of product components.
- Entry criteria:
 - (i) development plans available
 - (ii) baseline quality sufficient
- Exit criteria:
 - (i) functionality available
 - (ii) component tests completed





I. MR integration moment

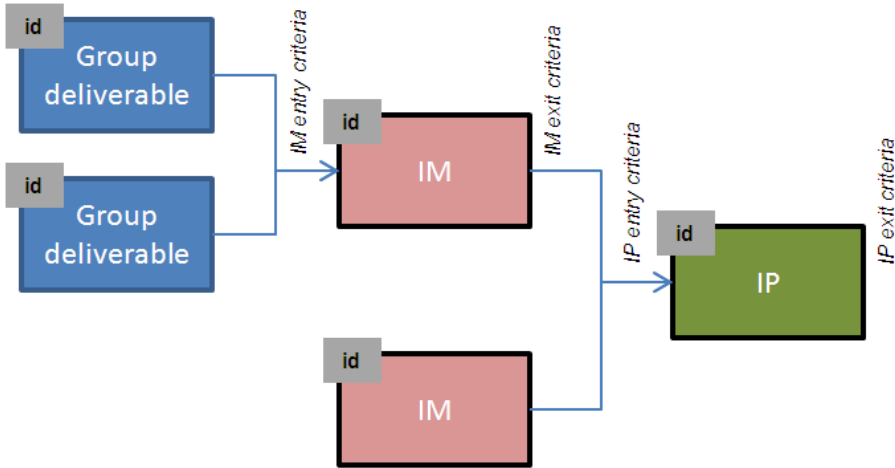

Integration Moment (IM):

- Goal:
 - integrate group deliverables in a product integration environment.
- Entry criteria:
 - (i) integration test plans available
 - (ii) product integration environment quality sufficient
 - (iii) received group deliverables accepted
- Exit criteria:
 - (i) integration test results available
 - (ii) integrated product available



Philips Healthcare MR integration concepts



I. MR integration point

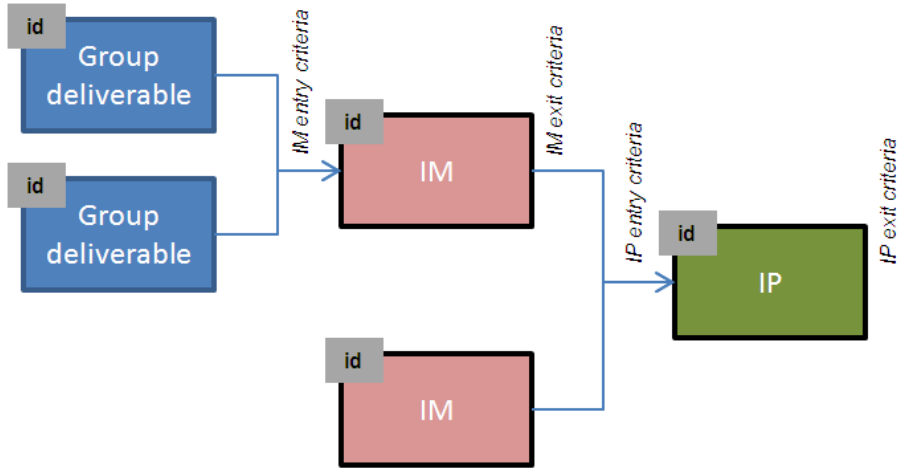

Integration Point (IP):

- Goal:
 - deliver an integrated product with a defined quality to enable system verification
- Entry criteria:
 - (i) QA tests planned
 - (ii) IM accepted
- Exit criteria:
 - QA test results available





II. MR integration interfaces

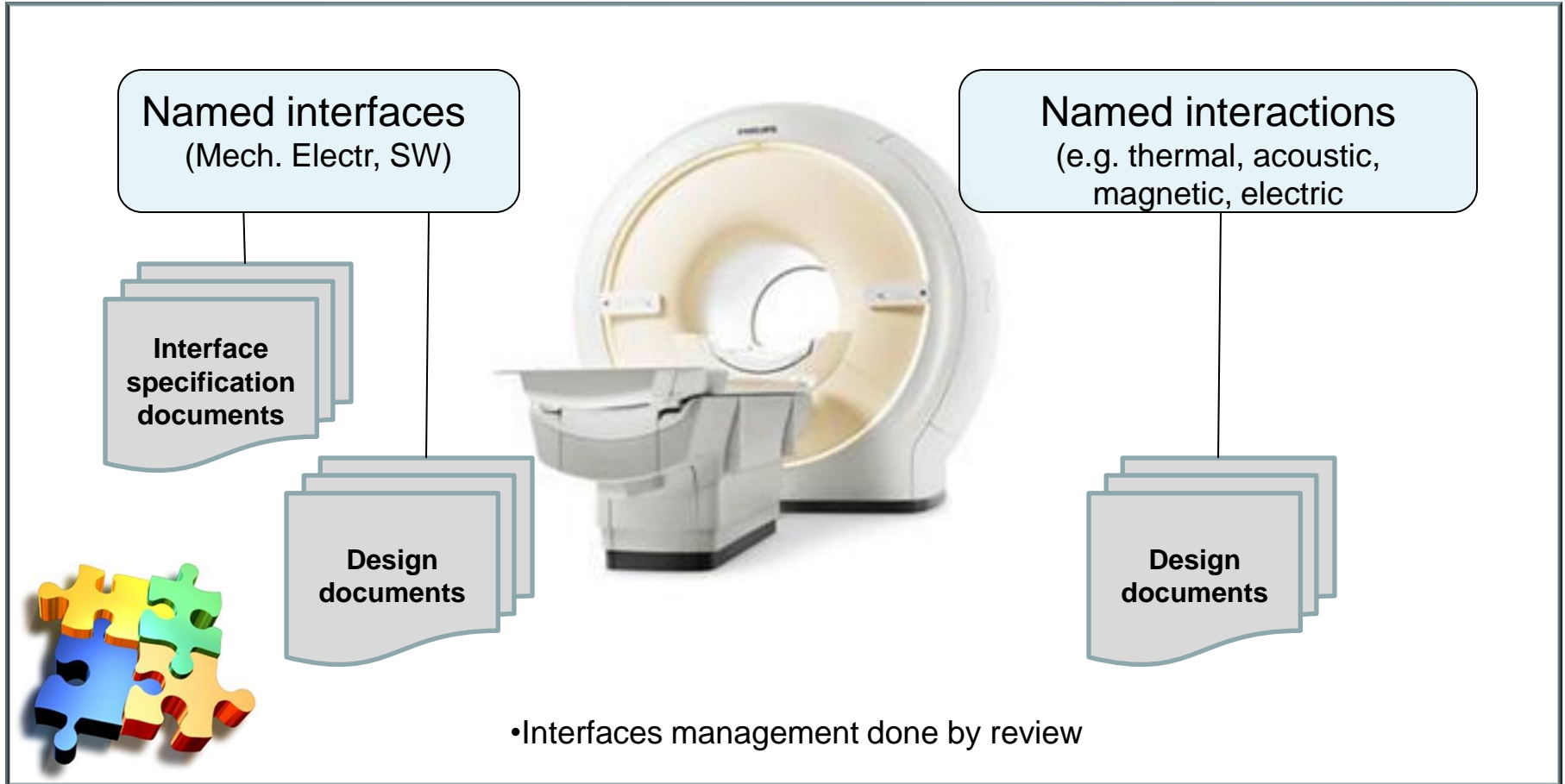

Philips Healthcare MR integration interfaces



III. MR integration environment

The top row contains four images of Philips MR scanners, each in a different configuration or view. The bottom row contains four images of interlocking puzzle pieces in blue, yellow, green, and orange. Each puzzle piece image has a white rounded rectangle highlighting a specific section, representing a product component that needs integration.

Various new product components require integration in various MR products

Philips Healthcare MR integration environment



III. MR integration testing

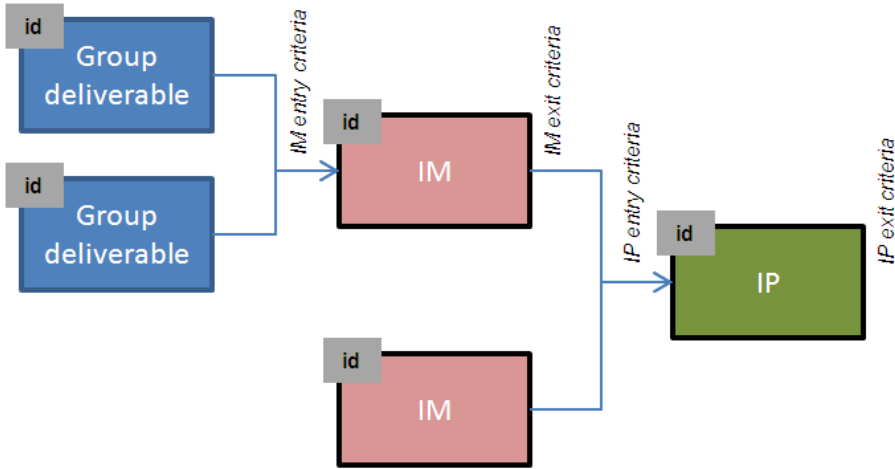

| | FUNCTIONAL | REGRESSION | CTQ |
|----------|---|----------------------------|---------------|
| Delivery | Verify component requirements | “1-hour” regression | |
| IM | Verify component Interfaces; verify component requirements | “2-hour” system regression | Component CtQ |
| IP | Verify system requirements | “4-hour” system regression | System CtQ |

Philips Healthcare MR integration environment



IV. MR integration process

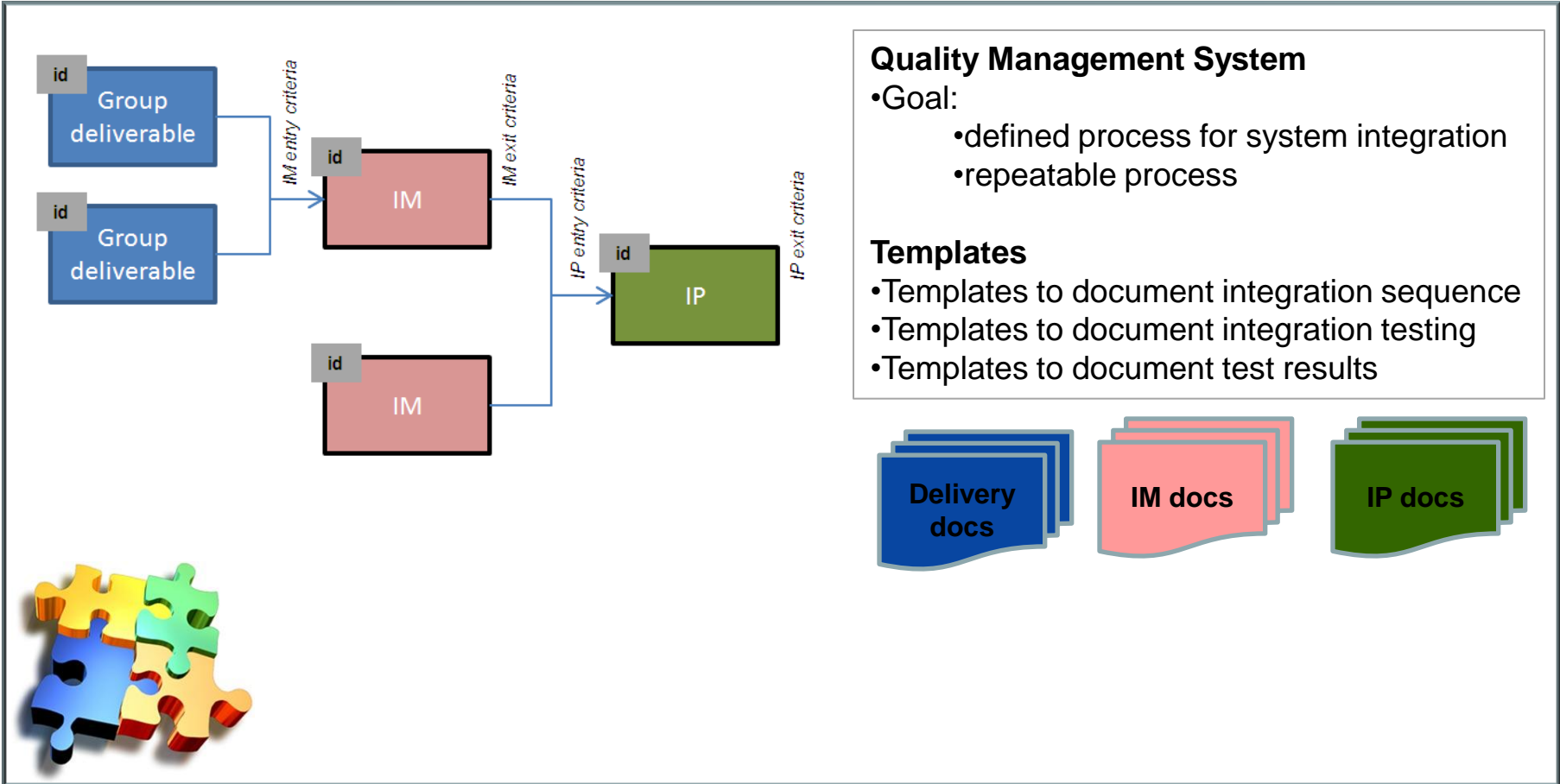

Philips Healthcare MR integration process



IV. MR integration documentation

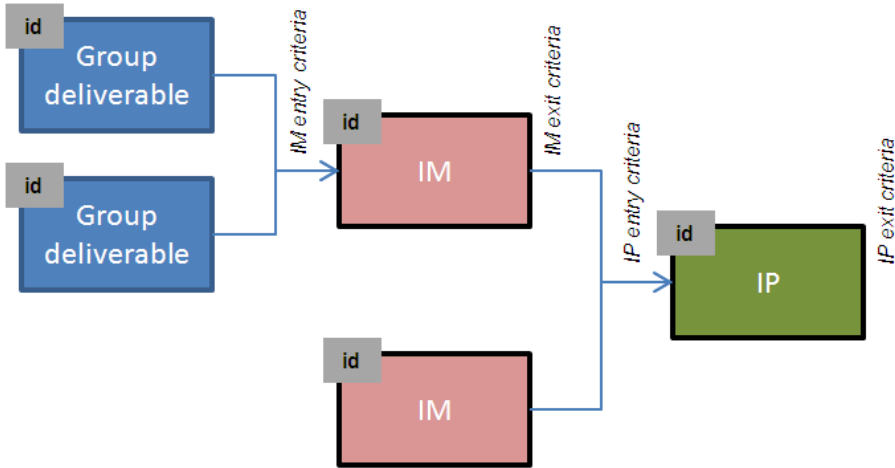

- Delivery test documents:**
- Detailed component test plan (reviewed)
 - Component test logs and reports
 - Archived in AGILE
- IM test documents:**
- Detailed integration test plan (reviewed)
 - Integration rest logs and reports
 - Archived in AGILE
- IP test documents:**
- Detailed test plan (reviewed)
 - Test logs and reports
 - Archived in AGILE





MR integration lessons learned

Technical content

- Integration sequence gives early insights in required deliverables
- Product architecture components recognized as building blocks for the integration sequence



Planning

- Integration sequence gives early insights in planning of integrated functionality
- Addition of planning data to integration sequence enables early planning feedback

Process

- Practiced in small-sized project and large-sized project.
- Set of templates under development

Philips Healthcare MR integration lessons learned

